

Model:
EF76V

SPECIFICATIONS:
 Year of Intro 2000
 Thrust 76LBS
 Volts 24VDC
 Amp Draw 0 to 33 amps
 Mount 20 Bow
 Speeds Variable

PARTS ORDERING & TECH ASSISTANCE
 MotorGuide Consumer Relations
 Phone 918-831-6989
 Fax 800-982-8093

Returned Goods must be accompanied with a Returned Goods Authorization. Contact MotorGuide Consumer Relations to obtain RGA.

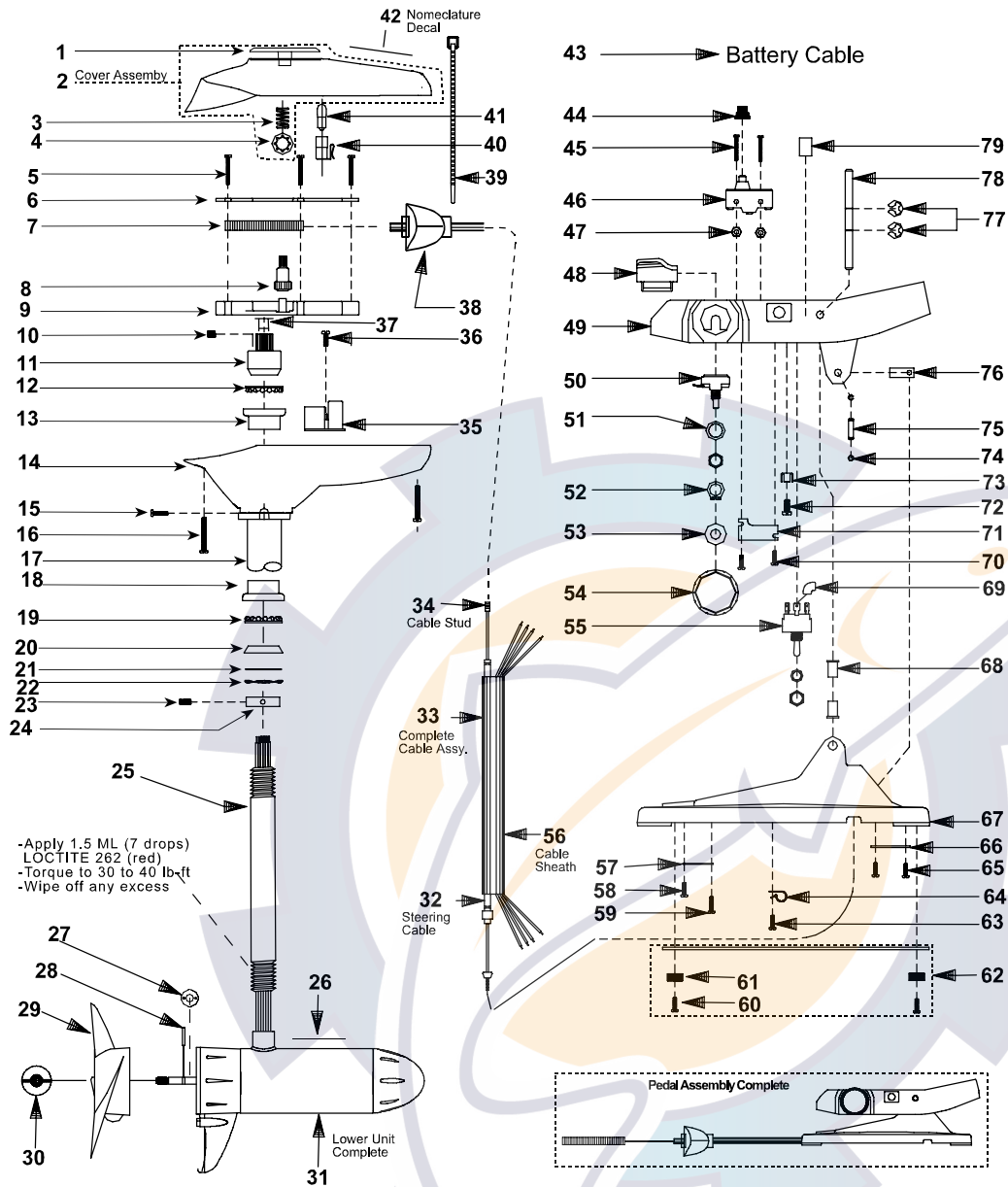

-Apply 1.5 ML (7 drops) LOCTITE 262 (red)
 -Torque to 30 to 40 lb-ft
 -Wipe off any excess

KEY	DESCRIPTION	PART #	KEY	DESCRIPTION	PART #	KEY	DESCRIPTION	PART #
1	RED INDICATOR	AF078-08	29	PROP	AF124-12	55	TOGGLE SWITCH 3 POSITIONS	PM3153-04
2	T/H COVER COMPLETE BLACK	EF053-17	30	PROP NUT	AR099-01	56	69" ELECTRIC CABLE JACKET	MM9006-03
3	COMPRESSION SPRING	AF014-01	31	MOTOR	TF397-02		63" ELECTRIC CABLE JACKET	MM9006-02
4	TINNERMAN CLIP	AF046-01	32	63" CONTROL CABLE STUD ASY	9377	57	CABLE PLATE	KP123-01
5	#6 RACK GUIDE SCREW	XF133-01	33	63" CONTROL CABLE ASY	9767	58	#6 SELF TAP SCREW	EK135-01
6	RACK GUIDE COVER	AF127-01		69" CONTROL CABLE ASY	AP327-16	59	6 X 1/2 SCREW	AF135-01
7	RACK	AP125-01		69" CONTROL CABLE ASY	AP327-18	60	6 X 1/2 SCREW	AF135-01
8	INDICATOR GEAR	AF069-01	34	CONTROL CABLE STUD	AP141-01	61	FOOT PEDAL PAD	KP023-01
9	RACK GUIDE	AF126-01	35	CIRCUIT BOARD	AF157-03	62	WEIGHT PLATE ASY	LP3123-01
10	1/4 NUT SET SCREW	AF142-01	36	#4 X 5/16 SS	XT141-01	63	6 X 1/2 SCREW	AF135-01
11	PM PINION NUT	AF398-01	37	PINION NUT BUSHING	AF021-01	64	CABLE CLAMP	KP036-01
12	BEARING	FM005-01	38	GROMMET	AP071-02	65	SCREW	IR133-01
13	BEARING CUP	AF007-01	39	CABLE TIE	AF030-01	66	BATTERY CLAMP	KP036-02
14	T/H BASE BLACK	EF004-15	40	LAMP HOLDER	AF394-01	67	FOOT PEDAL BASE	LP003-01
15	RIVET	LF111-03	41	LAMP	AF093-02	68	SHAFT BUSHING	KP021-01
16	#8 X 5/8 SCREW	AT141-01	42	NOMENCLATURE	JF056-18	69	INSULATING SLEEVE	AT080-01
17	42/50" OUTER TUBE	AF165-06	43	BATTERY CABLE ASY	XP328-03	70	6 X 1/2 SCREW	AF135-01
18	BEARING CUP	FM007-01	44	MICRO SWITCH BOOT	KP157-01	71	RETAINER PLATE	LP123-03
19	BEARING	FM005-01	45	#6 32 X 1 1/2 SCREW	LP135-01	72	#10X1/2 SCREW	RT133-03
20	BEARING RACE	AF006-03	46	MICRO SWITCH	AP151-01	73	ON SERT PAL NUT	TT098-03
21	O RING	AF063-01	47	6 - 32 NUT S.S	SP098-02	74	E RING	FP046-01
22	WAVE SPRING WASHER	AF171-01	48	MICRO BUTTON	LP026-01	75	CABLE PIVOT PIN	AP105-01
23	CONE SET SCREW	AF143-01	49	FOOT PEDAL	LP101-03	76	CABLE PIVOT	LP091-01
24	BEARING COLLAR	XF006-01	50	POTENTIOMETER	AP168-02	77	.312 E RING	BK046-02
25	42" .105 SS F/O COLUMN	AF049-09	51	LOCK WASHER 3/8	KP171-01	78	FOOT PEDAL ROCKER PIN	LP102-01
26	LOWER UNIT DECAL	ET060-07	52	GRIP RING	LP046-01	79	DECAL	LP057-09
27	MONOFILAMENT WASHER	AR175-01	53	NYLON WASHER	AK171-02			
28	PROP DRIVE PIN	BR102-02	54	SPEED KNOB	LP082-08			

LOWER UNIT BREAKDOWN

Model:
EF76V

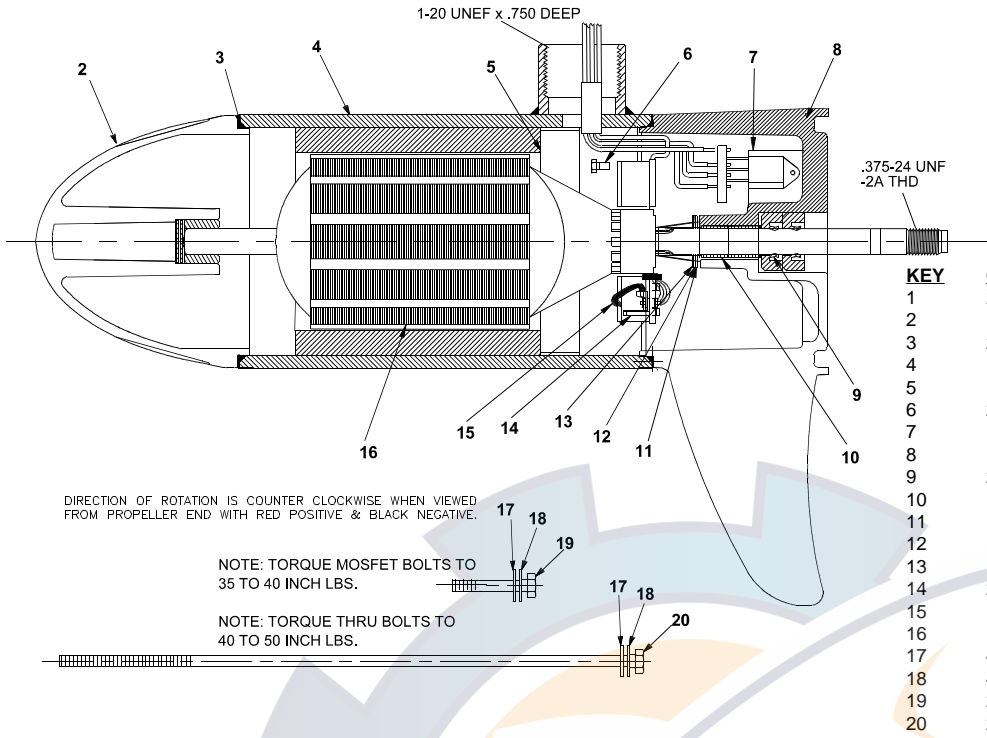

KEY	QTY	DESCRIPTION	PART NO.
1	X	MOTOR	TF397-02
2	1	NOSE CAP	XF3212-01
3	2	O RING SEAL	MR217-01
4	1	HOUSING ASY	AF3210-06
5	1	RETAINER	JF233-01
6	2	BRUSH CARD SCREW	MR228-01
7	1	DURA AMP MODULE	JF096-10
8	1	COMM CAP	XF3205-01
9	2	SHAFT SEAL	MR223-01
10	1	BEARING	MR206-01
11	1	NYLATRON WASHER	MR226-01
12	1	WASHER	MR227-01
13	1	E RING	MR219-02
14	2	BRUSH SPRINGS	XF214-01
15	1	BRUSH ASY LESS SPRING	XF3201-02
16	1	ARMATURE	TF3207-01
17	4	STATIC SEAL	MR222-01
18	4	THRU BOLT WASHER	MR216-02
19	2	DURA AMP SCREW	MR229-04
20	2	THRU BOLT	MR218-02

WIRING

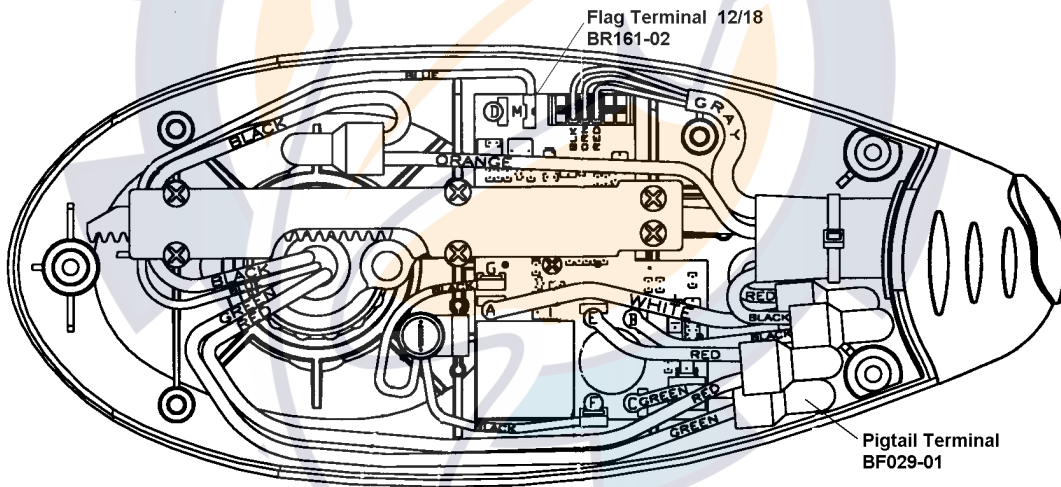

**⚠ SUBJECT TO DAMAGE BY STATIC ELECTRICITY
ASSEMBLE AT STATIC FREE WORK STATION!**

